



ROOFING ASSOCIATES

Exton, PA 19341 • (888) 594-6700 • Wexford, PA 15090
ShawnM@prarfg.com www.prarfg.com

Johns Manville Representative since 2019

TAPERED POLYISO. DESIGN GUIDE



INTRODUCTION TO THE TAPERED POLYISO. DESIGN GUIDE

The Tapered Polyiso. Design Guide was developed as a tool for Design Professionals and Contractors. The purpose of this guide is to act as a reference for tapered insulation design.

It is generally accepted that the principle of getting water off of the roof will enhance the long-term performance of the roof system. Designing an effective tapered insulation system is crucial in assuring this success. The key to successful tapered insulation design is doing the necessary analysis of the project to confirm field conditions such as dimensions, drain locations and deck slope verification for ponding water or deflection. Developing the design criteria for a roof drainage plan that will perform with the roofing system to drain the roof is critical **prior** to the bid process and roof system installation.

Design assistance services are offered as a courtesy to the roofing Design Professional and Contractors to ensure the project's success. We welcome the opportunity to assist you and your associates with developing a tapered insulation system. Please take the time to review the information contained within this document and contact Performance Roofing Associates (Johns Manville Sales Representative) at (888) 594-6700 if you have any questions.



Exton, PA 19341 • (888) 594-6700 • Wexford, PA 15090
ShawnM@prarfg.com www.prarfg.com



Published Feb. 2019

Introduction

Table of Contents

Chapter 1: Tapered Cross-Sections:

1/16"/ft. Slope (<i>NOT</i> Recommended for Level Roof Decks).....	6
4 Panel System	
8 Panel System	
1/8"/ft. Slope.....	7
4 Panel System	
6 Panel System	
1/4"/ft. Slope.....	8
2 Panel System (1/2" Min.)	
3 Panel System (1/2" Min.)	
2 Panel System (1" Min.)	
3 Panel System (1" Min.)	
1/2"/ft. Slope.....	9
1 Panel System	

** Not all tapered panels are commonly stocked. Those panels are considered Made to Order (MTO) and will need to be manufactured. This will add lead time to a project. Contact Performance Roofing at 888-594-6700 to make sure a product is in stock at Johns Manville's warehouse.*

Chapter 2: Tapered Layout Types:

Various Plan View Layouts.....	11
4 Directional Slope w/drains in line	
4 Directional Slope w/drains out of line	
Modified 4 Directional Slope w/ Cricket	
Modified 4 Directional Slope w/drains out of line	
Modified 4 Directional Slope w/Snub Nose Cricket	
2 Directional Slope w/Crickets	
Various Isometric View Layouts.....	12 & 13
1 Directional Slope to Gutter or Drip Edge	
1 Directional Slope with Crickets to Scupper	
2 Directional Slope with Crickets to Internal Roof Drain	
3 Directional Slope to Scupper	
4 Directional Slope to Internal Roof Drain	

Modified 4 Directional Slope w/ Diamond Cricke
Modified 4 Directional Slope w/ Kite Cricket
Multi-Directional Slope to Gutters

Backwash / Counter-Slope Layouts.....14

Backwash Mitered **INTO** Adjacent Flat Over Structural Slope
Backwash Mitered **ON** Adjacent Flat Over Structural Slope

Chapter 3: Crickets & Sumps

Cricket Definitions.....16

Valley Slope Calculations.....17

Calculation Examples.....18

Cricket Length to Width Ratios and Valley Slopes.....19

Isometric Cricket Valley Slope.....20

Cricket Types.....21

Full Diamond
Half Diamond 1
Half Diamond 2
Quarter Diamond
Kite
Snub Noes

Sumps.....22

Roof Drain at Interior of Roof
Roof Drain at Exterior of Roof

Chapter 4: Installation Instructions:

Cricket Installation Guides.....24

Full Diamond Cricket
Perimeter Cricket
Sawtooth Cricket
Snub Nose Cricket

Mitered Valley & Hip Guides for Field Cuts.....25

1 to 1 Valley
1 to 1 Hip

Appendix:

Suggestions.....27

Sample Roof Plan & Drawing Legend.....28

Glossary.....29 thru 33

Thermal Definitions.....34

Chapter 1

Tapered Cross-Sections

1/16"/ft. Slope (<i>NOT</i> Recommended for Level Roof Decks).....	6
4 Panel System	
8 Panel System	
1/8"/ft. Slope.....	7
4 Panel System	
6 Panel System	
1/4"/ft. Slope.....	8
2 Panel System (1/2" Min.)	
3 Panel System (1/2" Min.)	
2 Panel System (1" Min.)	
3 Panel System (1" Min.)	
1/2"/ft. Slope.....	9
1 Panel System	

**Not all tapered panels are commonly stocked. Those panels are considered Made to Order (MTO) and will need to be manufactured. This will add lead time to a project. Contact Performance Roofing at 888-594-6700 to make sure a product is in stock at Johns Manville's warehouse.*

Standard material is **Johns Manville ENRGY 3** Tapered and Flat Polyisocyanurate Roof Insulation. The Standard Tapered Panel Size is 4' x 4'.

1/16"/ft. taper is NOT recommended for use on level roof decks.

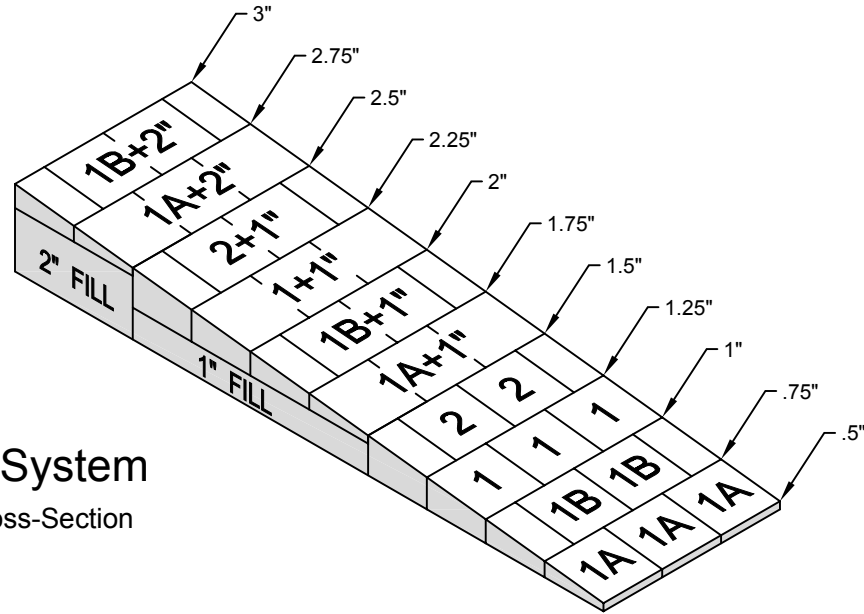

4 Panel System
Standard Cross-Section

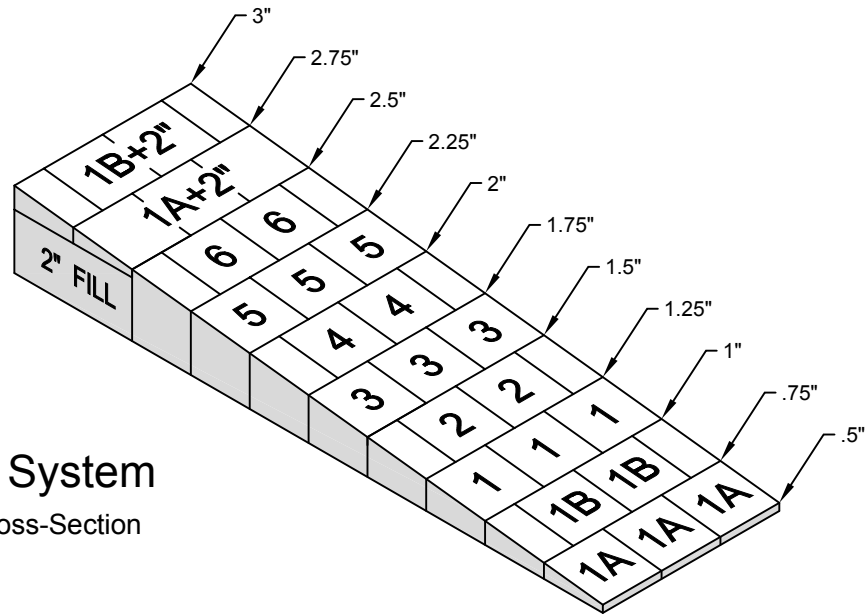

8 Panel System
Standard Cross-Section

* Not all tapered panels are stocked. Contact your Johns Manville Representative to confirm current availability.

Standard material is **Johns Manville ENRGY 3** Tapered and Flat Polyisocyanurate Roof Insulation. The Standard Tapered Panel Size is 4' x 4'.

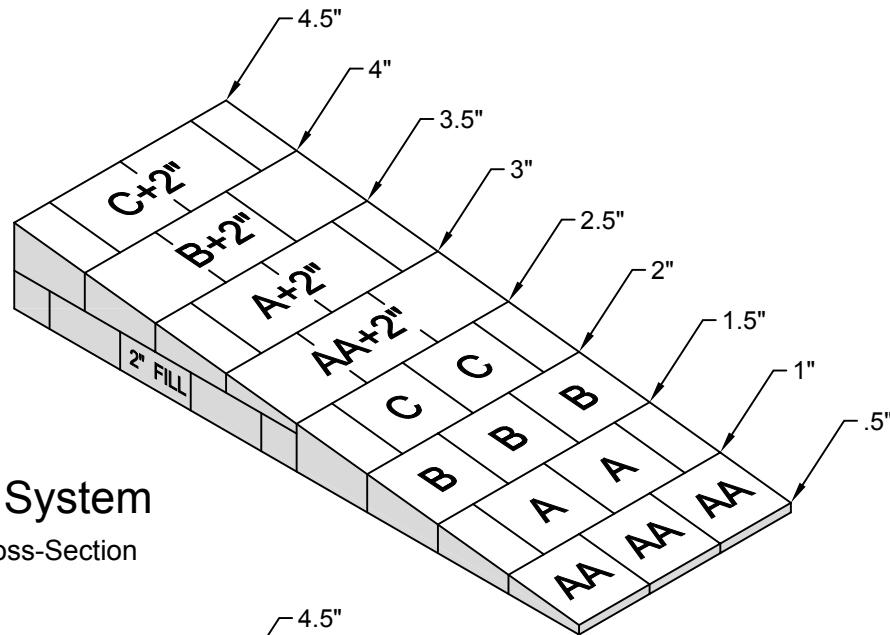

4 Panel System
Standard Cross-Section

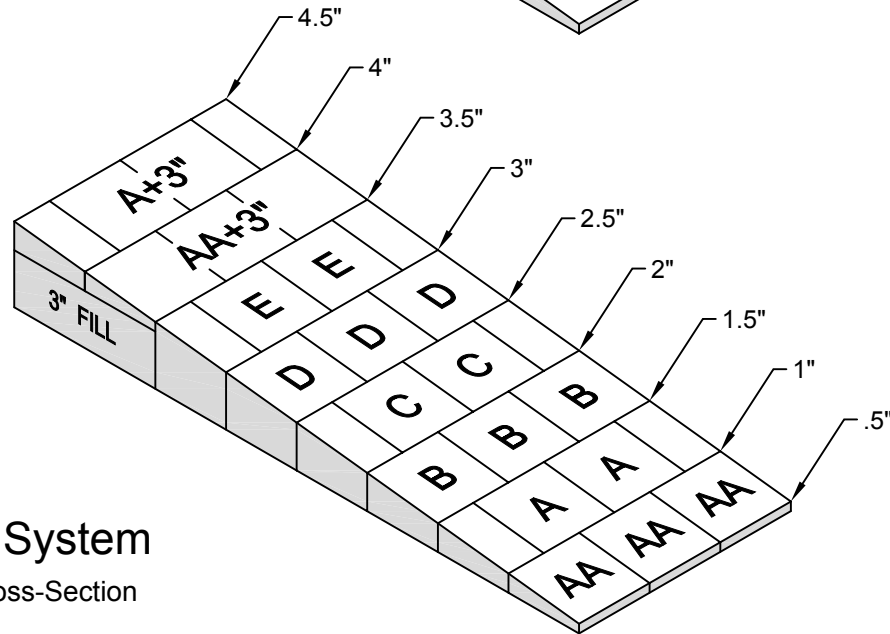

6 Panel System
Standard Cross-Section

* Not all tapered panels are stocked. Contact your Johns Manville Representative to confirm current availability.

Standard material is **Johns Manville ENRGY 3** Tapered and Flat Polyisocyanurate Roof Insulation. The Standard Tapered Panel Size is 4' x 4'.

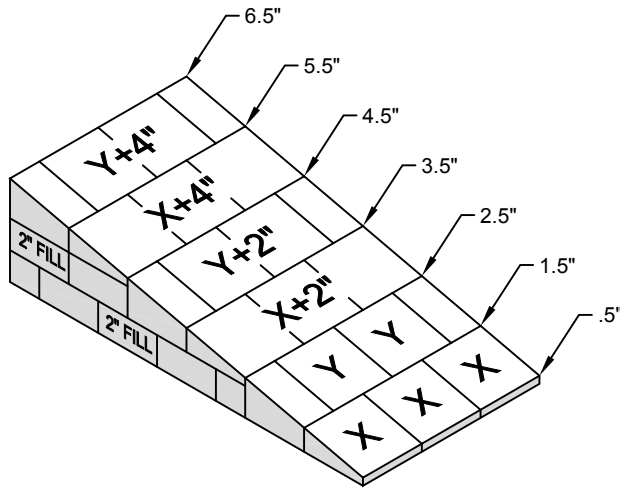

2 Panel System
(1/2" Min.)
Standard Cross-Section

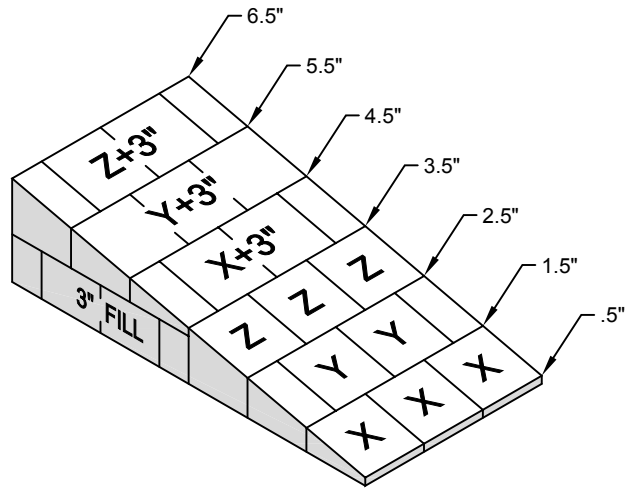

3 Panel System
(1/2" Min.)
Standard Cross-Section

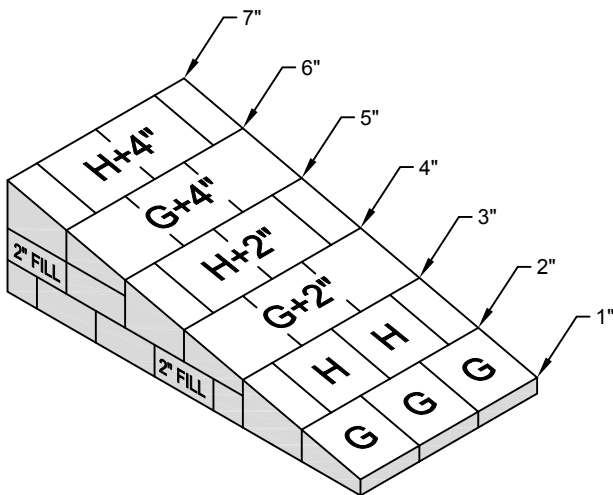

2 Panel System
(1" Min.)
Standard Cross-Section

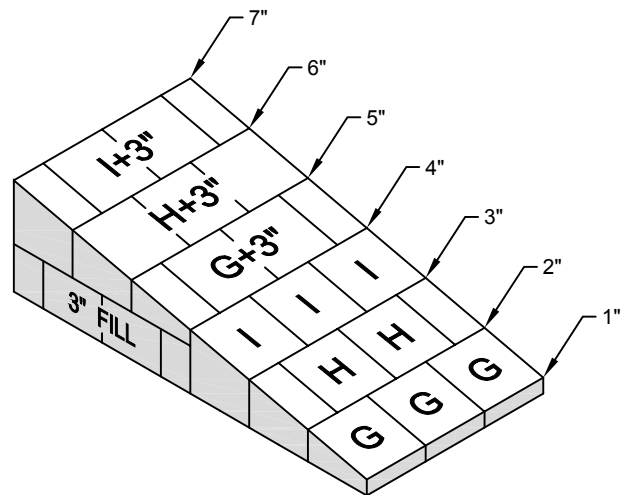

3 Panel System
(1" Min.)
Standard Cross-Section

* Not all tapered panels are stocked. Contact your Johns Manville Representative to confirm current availability.

Standard material is **Johns Manville ENRGY 3** Tapered and Flat Polyisocyanurate Roof Insulation. The Standard Tapered Panel Size is 4' x 4'.

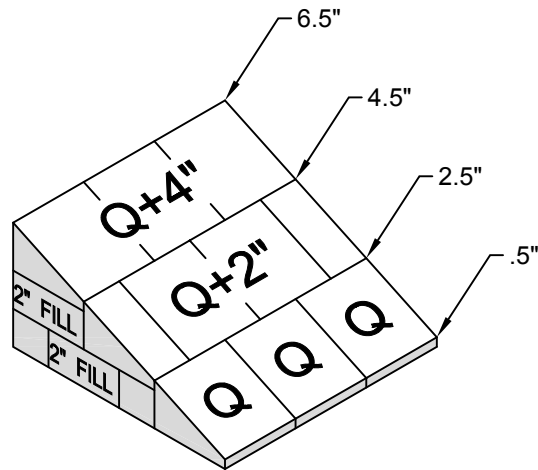

1 Panel System
Standard Cross-Section

* Not all tapered panels are stocked. Contact your Johns Manville Representative to confirm current availability.

Chapter 2

Tapered Layout Types

Various Plan View Layouts.....11

- 4 Directional Slope w/drains in line
- 4 Directional Slope w/drains out of line
- Modified 4 Directional Slope w/ Cricket
- Modified 4 Directional Slope w/drains out of line
- Modified 4 Directional Slope w/Snub Nose Cricket
- 2 Directional Slope w/Crickets

Various Isometric View Layouts.....12 & 13

- 1 Directional Slope to Gutter or Drip Edge
- 1 Directional Slope with Crickets to Scupper
- 2 Directional Slope with Crickets to Internal Roof Drain
- 3 Directional Slope to Scupper
- 4 Directional Slope to Internal Roof Drain
- Modified 4 Directional Slope w/ Diamond Cricket
- Modified 4 Directional Slope w/ Kite Cricket
- Multi-Directional Slope to Gutters

Backwash / Counter-Slope Layouts.....14

- Backwash Mitered **INTO** Adjacent Flat Over Structural Slope
- Backwash Mitered **ON** Adjacent Flat Over Structural Slope

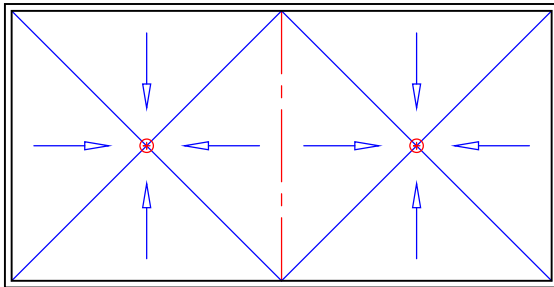

4 Directional Slope
w/drains in line

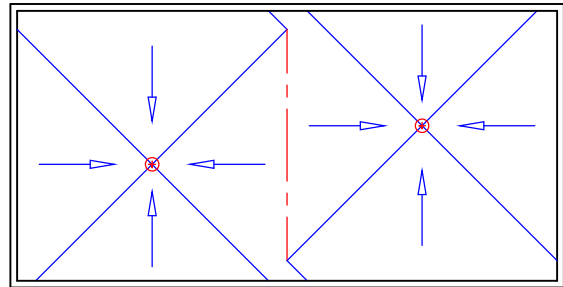

4 Directional Slope
w/drains out of line

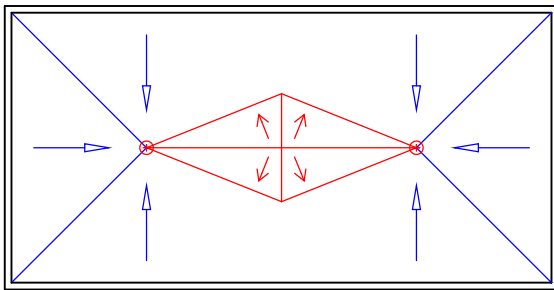

Modified 4 Directional
Slope w/ Cricket

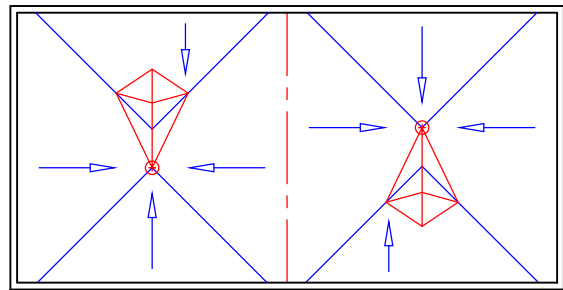

Modified 4 Directional Slope
w/drains out of line

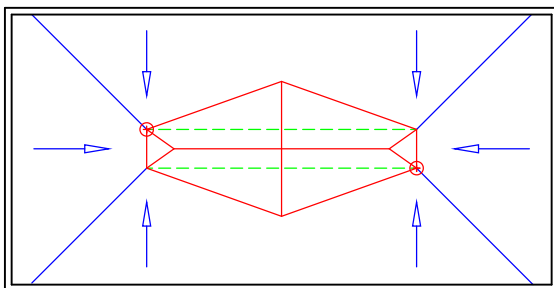

Modified 4 Directional Slope w/
Snub Nose Cricket

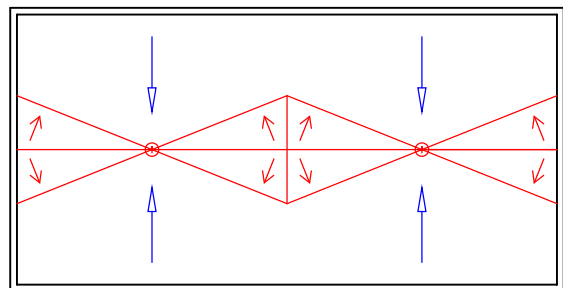

2 Directional Slope w/
Crickets

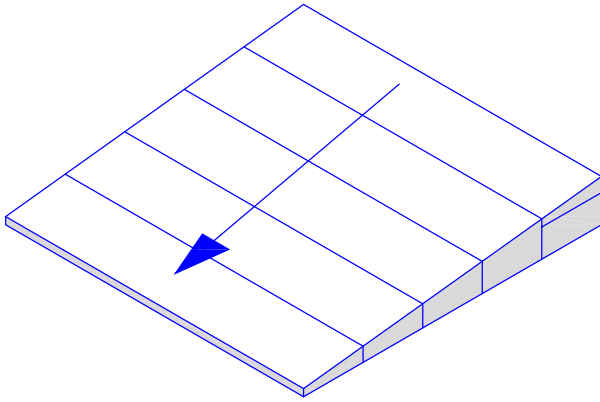

1 Directional Slope to Gutter or Drip Edge

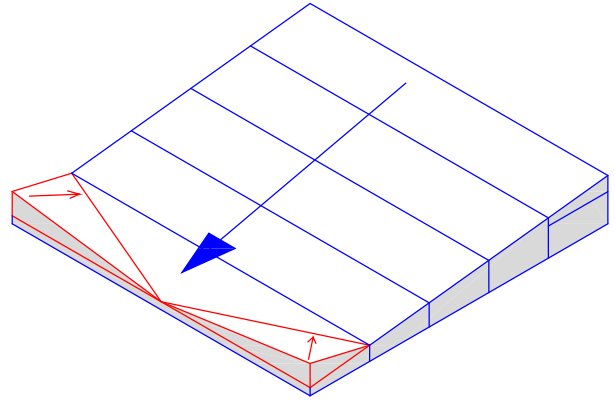

1 Directional Slope w/ Crickets to Scupper

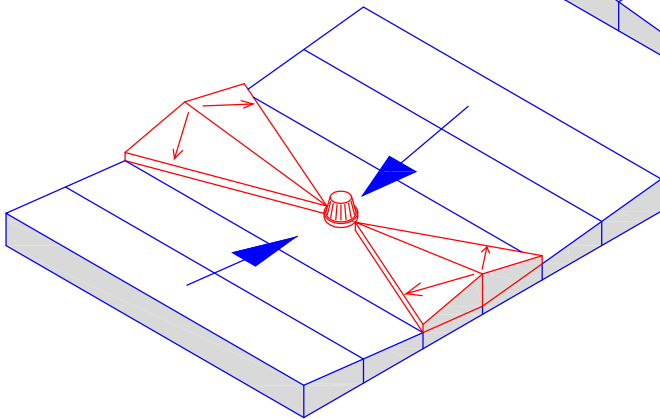

2 Directional Slope w/ Crickets to internal Roof Drain

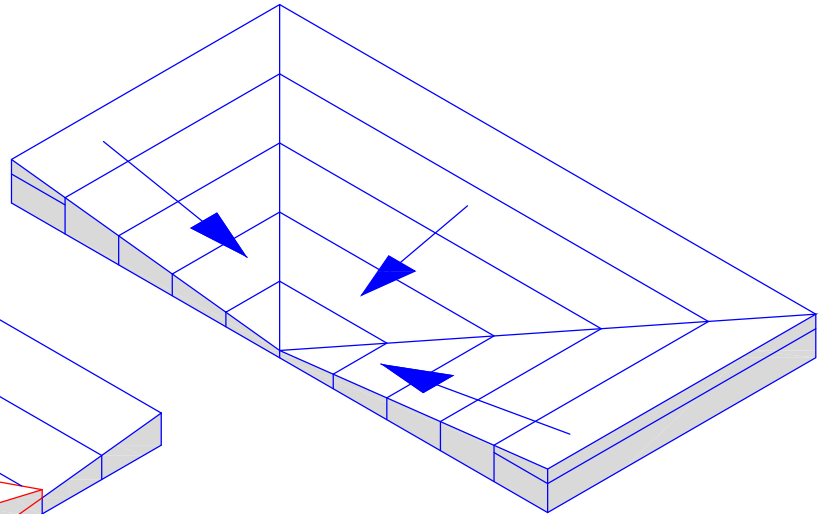

3 Directional Slope to Scupper

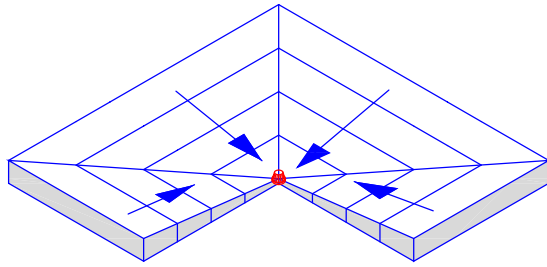

4 Directional Slope to
Internal Roof Drain

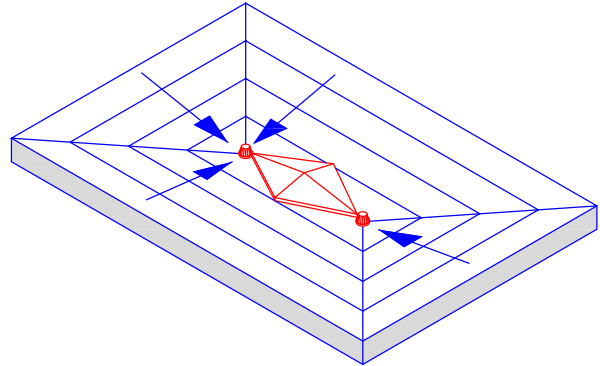

Modified 4 Directional
Slope w/ Diamond
Cricket

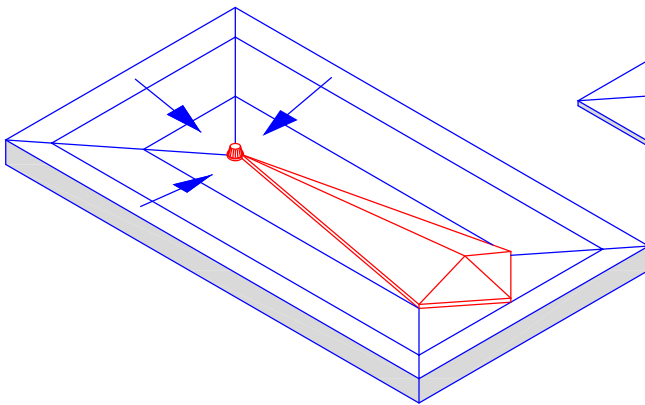

Modified 4 Directional
Slope w/ Kite Cricket

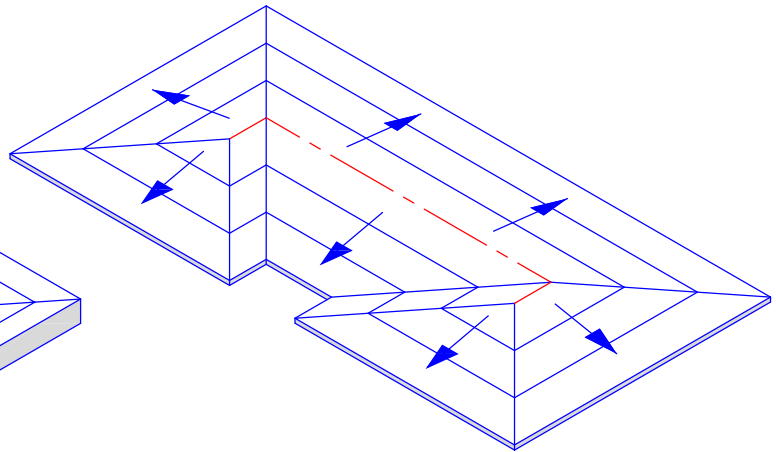

Multi Directional Slope
to Gutters

When roof drains are located a great distance away from a sloped roof edge (more than 48"), it can be more cost effective to use a tapered backwash. Tapered backwashes can also help reduce the insulation height at the roof edge.

Backwash Detail

Backwash Mitered **INTO** Adjacent Flat Over Structural Slope

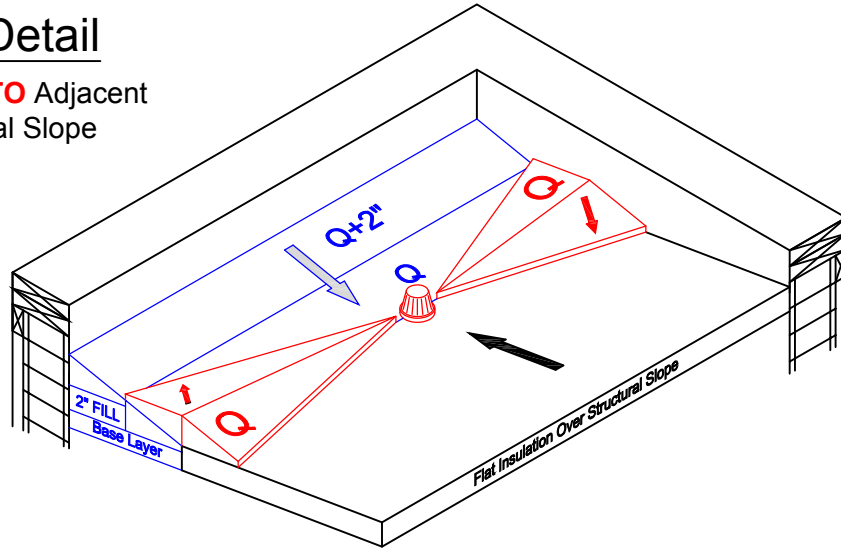

Backwash Detail

Backwash Overlaid **ON** Adjacent Flat Over Structural Slope

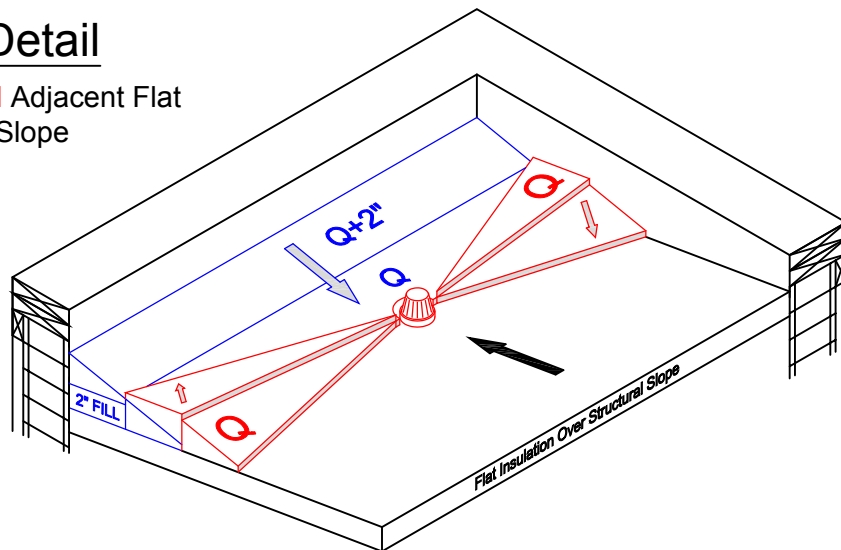

Chapter 3

Cricket & Sumps

Cricket Definitions.....	16
Valley Slope Calculations.....	17
Calculation Examples.....	18
Cricket Length to Width Ratios and Valley Slopes.....	19
Isometric Cricket Valley Slope.....	20
Cricket Types.....	21
Full Diamond	
Half Diamond 1	
Half Diamond 2	
Quarter Diamond	
Kite	
Snub Noes	
Sumps.....	22
Roof Drain at Interior of Roof	
Roof Drain at Exterior of Roof	

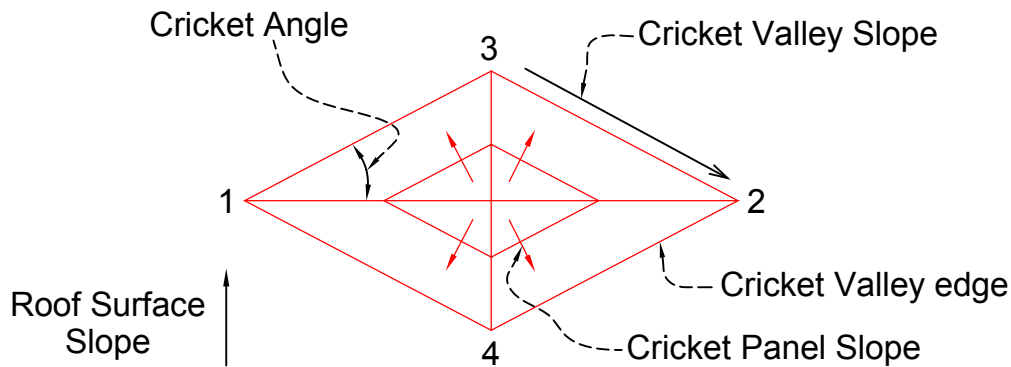

Roof Surface Slope The Slope that is created by the structure (i.e., concrete, steel or wood etc.), tapered insulation or a combination of the two.

Cricket Width Distance between Points 3 and 4

Cricket Length Distance between Points 1 and 2

Cricket Panel Slope The manufactured slope of the cricket panel. The Industry rule of thumb is that the cricket panel slope should be twice that of the roof surface slope. (i.e., If the roof surface slope is 1/4"/ft., the Cricket Panel Slope should be 1/2"/ft.) There are exceptions to this rule, please call us for further information.

Cricket Valley Slope The slope created along the valley edge of the cricket as a result of the cricket width, length, angle and the roof surface slope.

Cricket Angle The angle between line 1-2 (cricket length) and 1-3 (cricket valley). As this angle increases, the cricket valley slope increases resulting with more effective drainage.

$$\text{Cricket Valley Slope} = \frac{\text{Elevation difference along valley}}{\text{Length of Cricket Valley}}$$

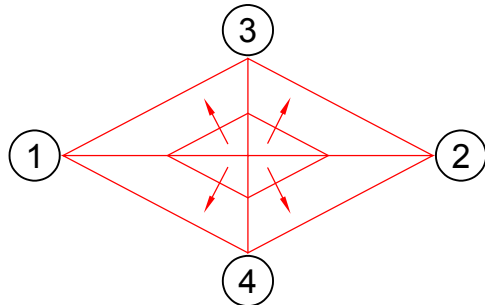

Full Diamond Cricket

$$\begin{aligned} &\text{Elevation Difference} \\ &(\text{Roof Surface Slope} \times (1/2 \times \text{Cricket Width})) \\ &(1/8"/\text{ft.} / 1/4"/\text{ft.} / 1/2"/\text{ft.}) \times (1/2 \times \text{Points } \textcircled{3} \text{ to } \textcircled{4}) \end{aligned}$$

$$\begin{aligned} &\text{Length of Cricket Valley} \\ &(\text{Points } \textcircled{2} \text{ to } \textcircled{3}) \end{aligned}$$

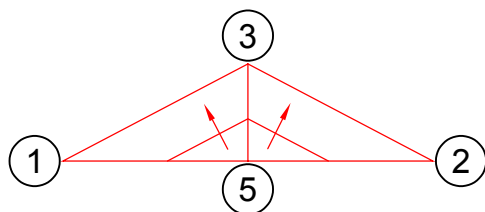

Half Diamond Cricket

$$\begin{aligned} &\text{Elevation Difference} \\ &(\text{Roof Surface Slope} \times \text{Cricket Width}) \\ &(1/8"/\text{ft.} / 1/4"/\text{ft.} / 1/2"/\text{ft.}) \times (\text{Points } \textcircled{3} \text{ to } \textcircled{5}) \end{aligned}$$

$$\begin{aligned} &\text{Length of Cricket Valley} \\ &(\text{Points } \textcircled{2} \text{ to } \textcircled{3}) \end{aligned}$$

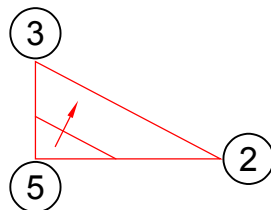

Quarter Diamond Cricket

$$\begin{aligned} &\text{Elevation Difference} \\ &(\text{Roof Surface Slope} \times \text{Cricket Width}) \\ &(1/8"/\text{ft.} / 1/4"/\text{ft.} / 1/2"/\text{ft.}) \times (\text{Points } \textcircled{3} \text{ to } \textcircled{5}) \end{aligned}$$

$$\begin{aligned} &\text{Length of Cricket Valley} \\ &(\text{Points } \textcircled{2} \text{ to } \textcircled{3}) \end{aligned}$$

Example A

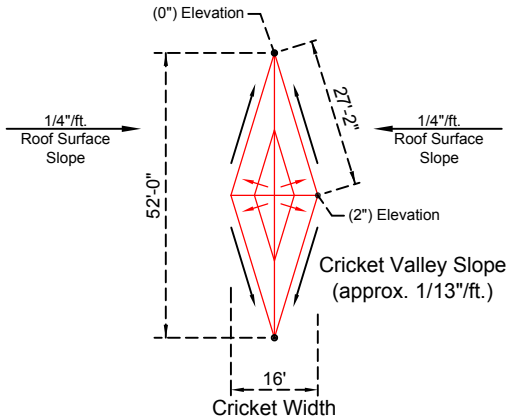

$$\frac{2" \text{ Elevation Difference}}{\left(\left(\frac{1}{4}"/\text{ft. Roof Surface Slope}\right) \times 8' \text{ (16' cricket width} \times 0.5)\right)} \div \frac{27'-2" \text{ (Cricket Valley Length)}}{= \text{approximate } \underline{1/13}"/\text{ft. Cricket Valley Slope}}$$

Example B

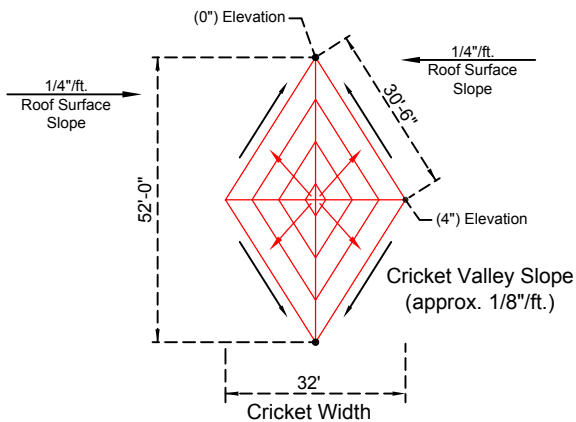

$$\frac{4" \text{ Elevation Difference}}{\left(\left(\frac{1}{4}"/\text{ft. Roof Surface Slope}\right) \times 16' \text{ (32' cricket width} \times 0.5)\right)} \div \frac{30'-6" \text{ (Cricket Valley Length)}}{= \text{approximate } \underline{1/8}"/\text{ft. Cricket Valley Slope}}$$

The above examples very clearly show the importance of proper cricket widths. The Cricket in example B virtually doubled the valley slope shown in example A.

Another point to consider is **IF** the Roof Surface slope was 1/8"/ft. in the above examples, the resulting valley slopes would be 1/26"/ft. in example A and 1/16"/ft. in example B. Call us with any questions or concerns.

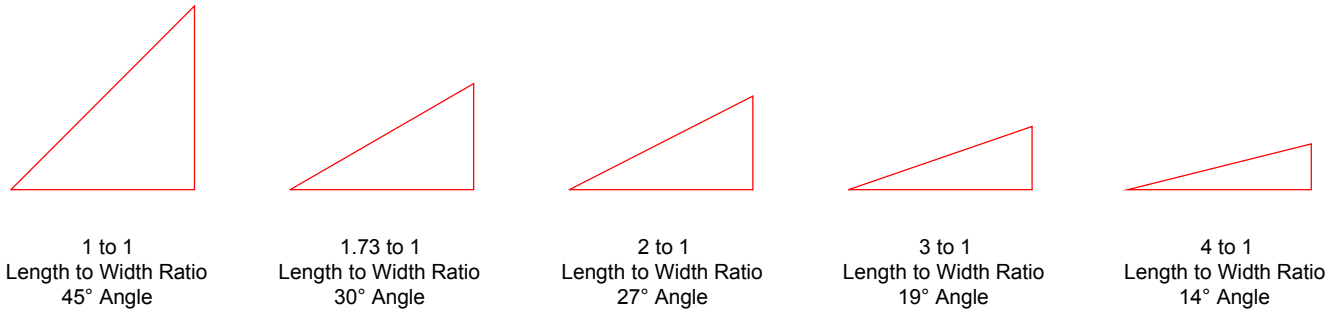
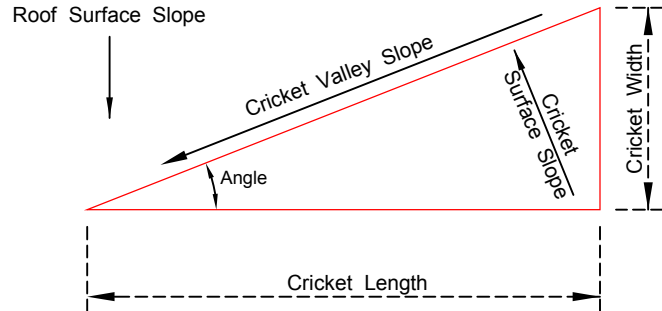

Roof Surface Slope (inches / ft.)	1 to 1 Length to Width Ratio		1.73 to 1 Length to Width Ratio		2 to 1 Length to Width Ratio		3 to 1 Length to Width Ratio		4 to 1 Length to Width Ratio	
	Cricket Angle	Valley Slope	Cricket Angle	Valley Slope	Cricket Angle	Valley Slope	Cricket Angle	Valley Slope	Cricket Angle	Valley Slope
1/16"/ft.	45 °	1/25"/ft.	30 °	1/32"/ft.	27 °	1/36"/ft.	19 °	1/51"/ft.	14 °	1/66"/ft.
1/8"/ft.	45 °	1/11"/ft.	30 °	1/16"/ft.	27 °	1/18"/ft.	19 °	2/51ft.	14 °	1/33"/ft.
3/16"/ft.	45 °	2/13"/ft.	30 °	3/32"/ft.	27 °	1/12"/ft.	19 °	3/51"/ft.	14 °	3/66"/ft.
1/4"/ft.	45 °	2/11"/ft.	30 °	1/8"/ft.	27 °	1/9"/ft.	19 °	4/51"/ft.	14 °	2/33"/ft.
3/8"/ft.	45 °	4/15"/ft.	30 °	3/16"/ft.	27 °	1/6"/ft.	19 °	5/51"/ft.	14 °	1/11"/ft.
1/2"/ft.	45 °	4/11"/ft.	30 °	1/4"/ft.	27 °	2/9"/ft.	19 °	6/51"/ft.	14 °	4/33"/ft.
3/4"/ft.	45 °	8/15"/ft.	30 °	3/8"/ft.	27 °	1/3"/ft.	19 °	7/51"/ft.	14 °	2/11"/ft.
1"/ft.	45 °	8/11"/ft.	30 °	1/2"/ft.	27 °	4/9"/ft.	19 °	8/51"/ft.	14 °	8/33"/ft.

The above cricket valley slopes and angles are approximate and are intended to show the relationship between the length to width ratios and valley slopes. This information is not a recommendation, it is rather a factual representation to help industry professionals properly size crickets for commercial roofing.

The information clearly shows the need for wider crickets when using low "roof surface slopes" in order to achieve adequate valley slopes. Projects that utilize the same cricket width all over the roof will have valley slopes that vary considerably. While this approach may be easier to install, it does not achieve consistent drainage.

The same length to width ratio should not be used for different roof surface slopes without first realizing the effect on the valley slope. For example, a cricket with a length to width ratio of 4 to 1 installed on 1/4"/ft. roof surface slope has a valley slope of approx. 2/33"/ft.(approx. 1/16"/ft.). The same cricket installed on 1/8"/ft. roof surface slope has a valley slope of approx. 1/33"/ft. This is why each unique roof surface slope should have its own unique length to width ratio for crickets.

One final point, increasing the cricket surface slope has absolutely no effect on the valley slope.

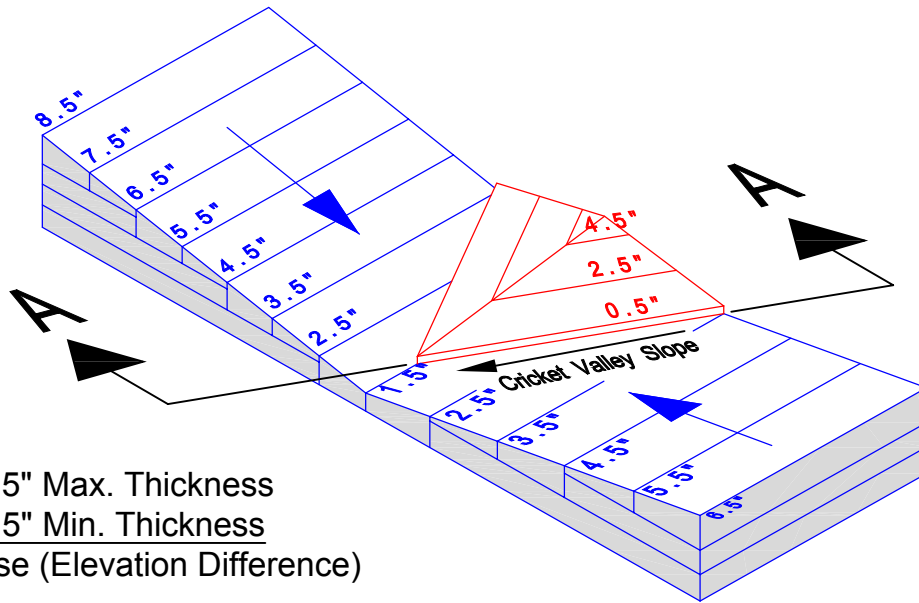

3.5" Max. Thickness
 - 1.5" Min. Thickness
 = 2.0" Rise (Elevation Difference)

2.0" ÷ 16'-0"
 = 1/8"/ft. Cricket Valley Slope

If the roof surface slope was 1/8"/ft. in this example, the rise would have been 1.0" and the valley slope would have been 1/16"/ft.

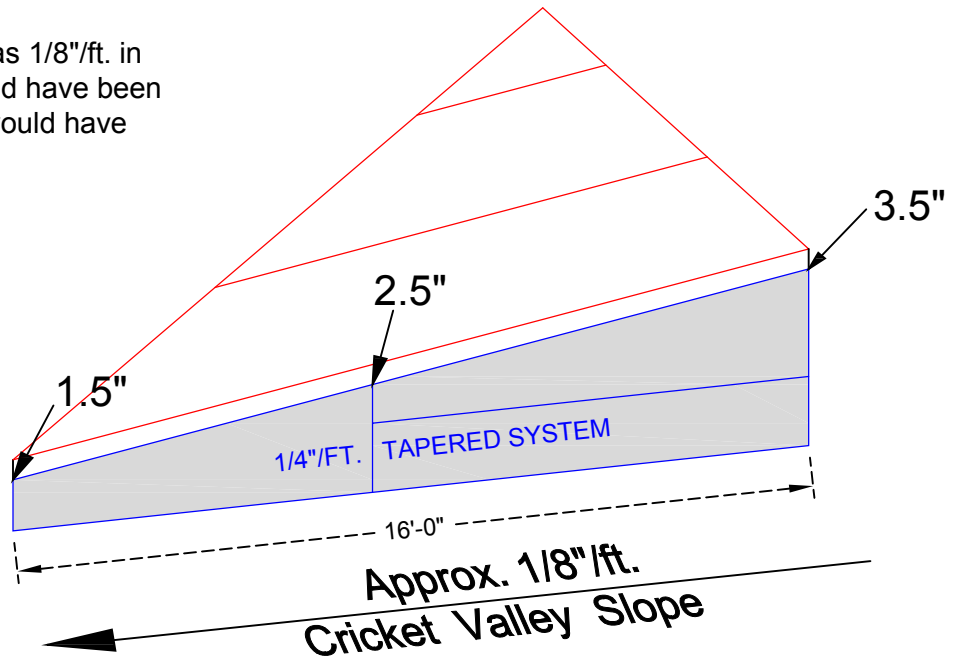

Detail A

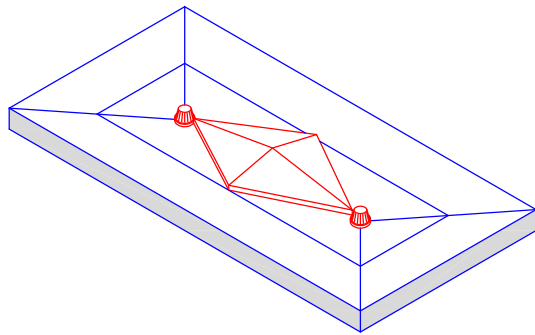

Full Diamond Cricket

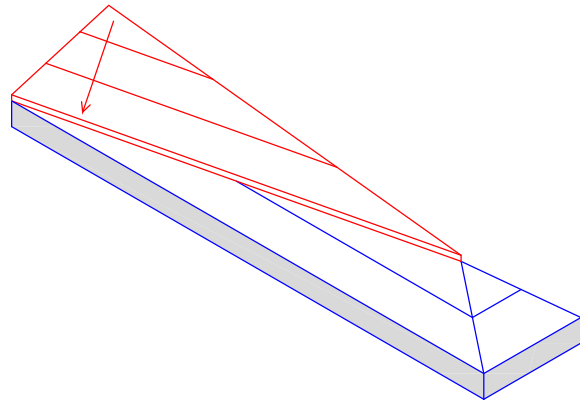

Quarter Diamond Cricket

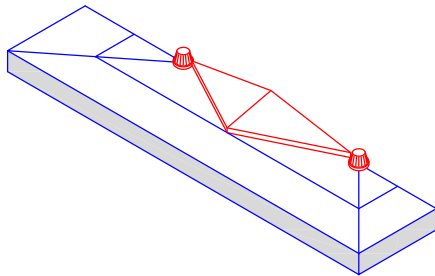

Half Diamond Cricket - 1

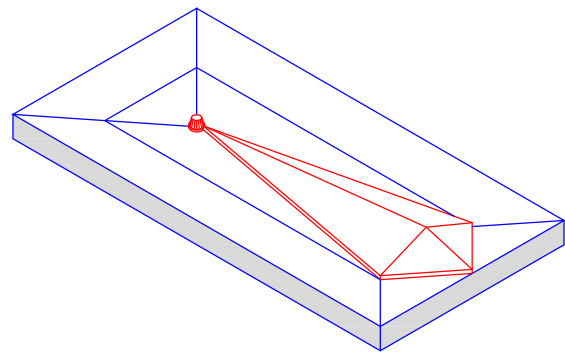

Kite Cricket

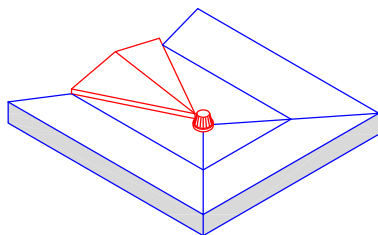

Half Diamond Cricket - 2

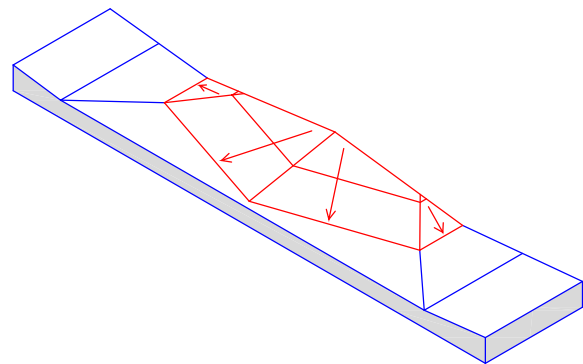

Snub Nose Cricket

Polyisocyanurate Sumps

Most roofs can benefit from incorporating some type of tapered polyiso. sump, but they're not always necessary or required. Many factors can dictate the need or benefit of sumps including, but not limited to; roof system type, roof slope, drain placement and flat insulation thickness. There are too many factors and scenarios to list, so below are a handful of examples of when they would be acceptable to use and how they can be constructed. Contact your Johns Manville Representative to discuss your specific project needs.

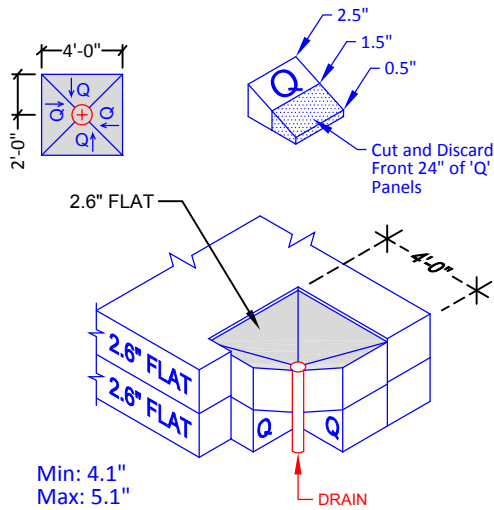

SUMP SAMPLE 1

-- ROOF DRAIN AT INTERIOR OF ROOF --

1/4"/FT. STRUCTURAL SLOPE
4'x4' - 1/2"/ft. SLOPE SUMP - R30 FLAT

(THIS SCENARIO ALMOST ALWAYS
REQUIRES A SUMP AS THE ROOF DRAIN IS
LIKELY TO NEVER BE LOCATED AT THE
LOWEST POINT OF THE ROOF)

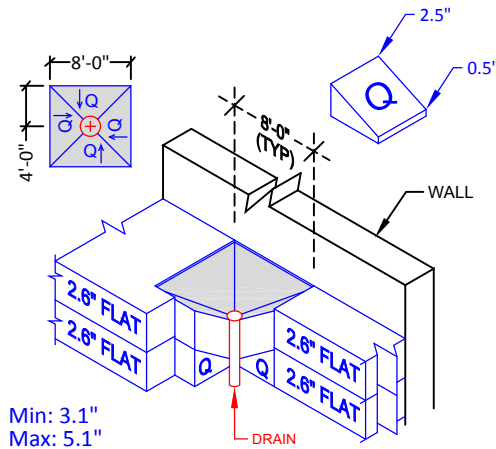

SUMP SAMPLE 2

-- ROOF DRAIN AT EXTERIOR OF ROOF --

1/4"/FT. STRUCTURAL SLOPE
8'x8' - 1/2"/ft. SLOPE SUMP - R30 FLAT

(SUMPS ARE BENEFICIAL, BUT ARE NOT
NECESSARY IF A SAWTOOTH CRICKET IS
INSTALLED)

Chapter 4

Installation Instructions

Cricket Installation Guides.....24

- Full Diamond Cricket
- Perimeter Cricket
- Sawtooth Cricket
- Snub Nose Cricket

Mitered Valley & Hip Guides for Field Cuts.....25

- 1 to 1 Valley
- 1 to 1 Hip

Full Diamond Cricket

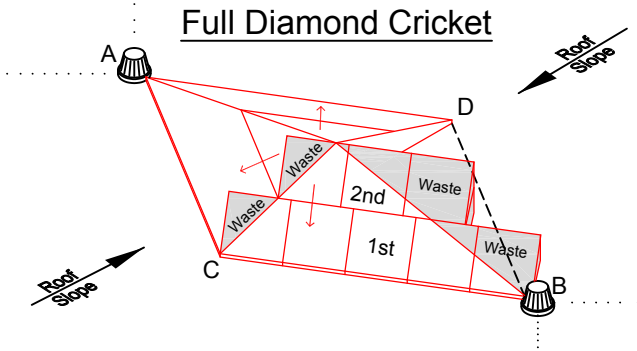

1. Measure the distance between the drains and verify with those on shop drawing.
2. Chalk lines for the axis (lines AB & CD) of the diamond shape.
3. Chalk line all four cricket valleys AC, CB, BD and DA.
4. Install the 1st panels by laying the 0.5" thin edge on the chalked valley lines as shown.
5. Next, install the 2nd panels by laying their thin edge tightly up against the thick edge of the 1st panels.
6. Discard waste portions of the panels as indicated.
7. Repeat steps 1 thru 6 for the remaining crickets.

Perimeter Cricket

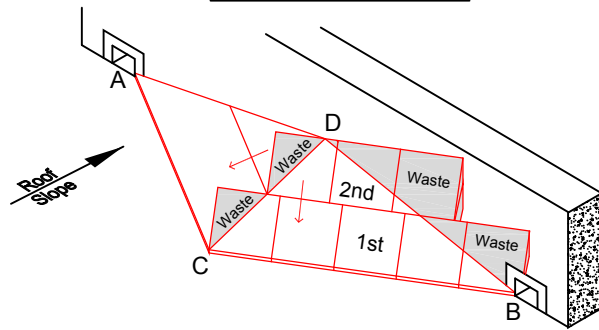

1. Measure the distance between the scuppers and verify with those on shop drawing.
2. Find the midpoint between the scuppers and locate point C.
3. Chalk lines between points AC, CB.
4. Install the 1st panels by laying the 0.5" thin edge on the chalked valley lines as shown.
5. Next, install the 2nd panels by laying their thin edge tightly up against the thick edge of the 1st panels.
6. Discard waste portions of the panels as indicated.
7. Repeat steps 1 thru 6 for the remaining crickets.

Sawtooth Cricket

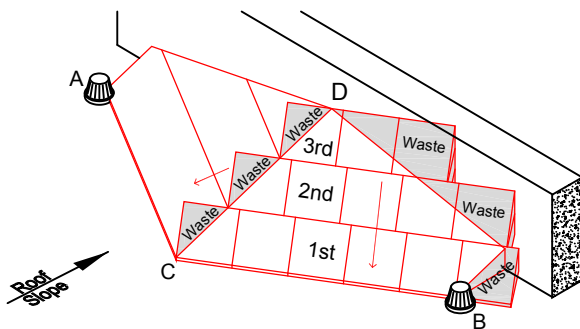

1. Measure the distance between the scuppers and verify with those on shop drawing.
2. Find the midpoint between the scuppers and locate point C.
3. Chalk lines between points AC and CB.
4. Install the 1st panels by laying the 0.5" thin edge on the chalked valley lines as shown.
5. Next, install the 2nd panels by laying their thin edge tightly up against the thick edge of the 1st panels. Similar for next panels installed.
6. Discard waste portions of the panels as indicated.
7. Repeat steps 1 thru 6 for the remaining crickets.

Snub Nose Cricket

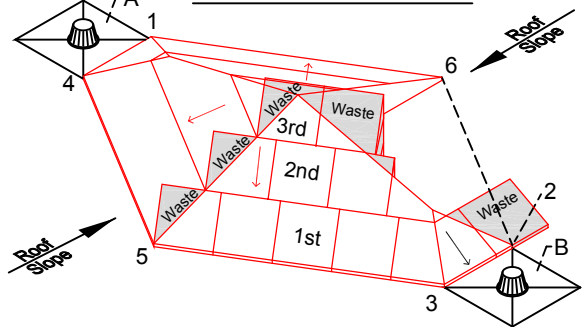

1. Measure the distance between edge of sump A & sump B (1-2 & 3-4) and verify with those on shop drawing.
2. Chalk lines between the sumps/drains (1-2 & 3-4) and between points 5 & 6.
3. Chalk line all six cricket valleys 1-6, 6-2, 2-3, 3-5, 5-4 & 4-1.
4. Install the 1st panels by laying the 0.5" thin edge on the chalked valley lines as shown.
5. Next, install the 2nd panels by laying their thin edge tightly up against the thick edge of the 1st panels. Similar for next panels installed.
6. Discard waste portions of the panels as indicated.
7. Repeat steps 1 thru 6 for the remaining crickets.

Valley Miter

Cuts used to miter two panels of the same slope together

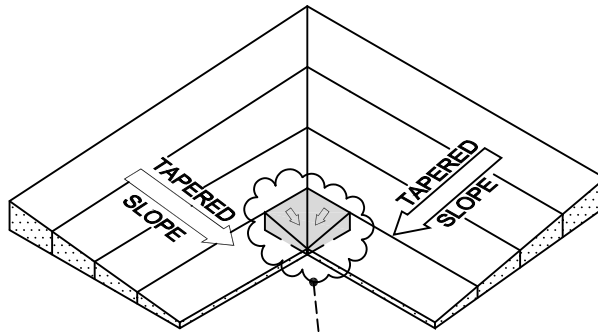

The remaining portions leftover from the valley miter can be used to create a hip miter, if one is required elsewhere in the tapered layout.

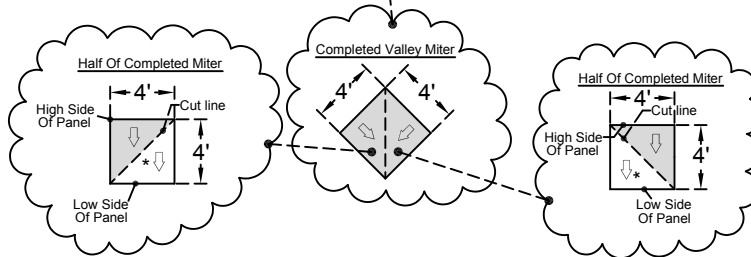

Hip Miter

Cuts used to miter two panels of the same slope together

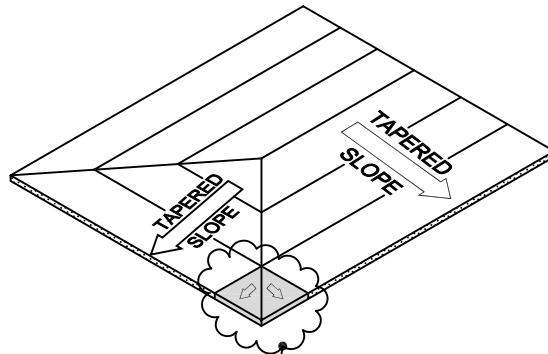

* The remaining portions leftover from the hip miter can be used to create a valley miter, if one is required elsewhere in the tapered layout.

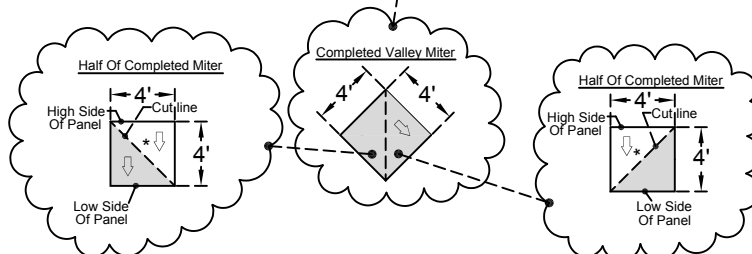

Appendix

Suggestions.....	27
Sample Roof Plan & Drawing Legend.....	28
Glossary.....	29 thru 33
Thermal Definitions.....	34

1. Clearly note the design intentions for each roof area on the roof plan by using unique arrows or unique shading and a corresponding legend. This includes those areas that are to receive tapered insulation, tapered cricket insulation and areas that are structurally sloped. Always indicate the net slope or material slope desire. For example, if a roof is structurally sloped at 1/4"/ft., specify 1/2"/ft. crickets. If new tapered insulation is to be added to an existing material or structural slope that should be clearly indicated.
2. The total required minimum thickness of a tapered insulation system should be clearly specified. There can be numerous ways to achieve a specified minimum thickness which includes using a tapered insulation panel with the required starting thickness or a tapered panel can be used in conjunction with a flat insulation board. The thinnest available thickness for tapered polyiso. is 0.5".
3. When a specific R-Value is required or desired, specify minimum or average, NOT both!
4. Roof drains should always be located as close as possible to the lowest point of the roof.
5. Determine if drains can be relocated or added to increase symmetry for the tapered system layout. Tapered systems can become very labor intensive to install when existing drains are sporadically located.
6. The 4 directional tapered systems can provide better drainage than 2 directional tapered systems with crickets. However, every roof has its own unique conditions and those conditions may require the use of a 2 directional tapered system.
7. The ratio of a cricket's length to width has an important impact on the slope that results in the cricket valley. See Chapter 3 for detailed information regarding cricket valley slope, cricket length to width ratios and cricket angles.
8. Cricket material slope should be greater than the roof surface slope. For example, if the roof surface slope is 1/2"/ft., the cricket material slope should be no less than 3/4"/ft., resulting in a 1/4"/ft. net positive slope.
9. All major roof penetrations should be shown on a roof plan. In addition, the supporting structure type (e.g. curb, dunnage, pipe support, etc.) should be clearly indicated as this will impact the tapered system design. Try to avoid placing roof curbs or any penetrations in a drain valley or tapered system low point.

Sample Roof Plan & Drawing Legend

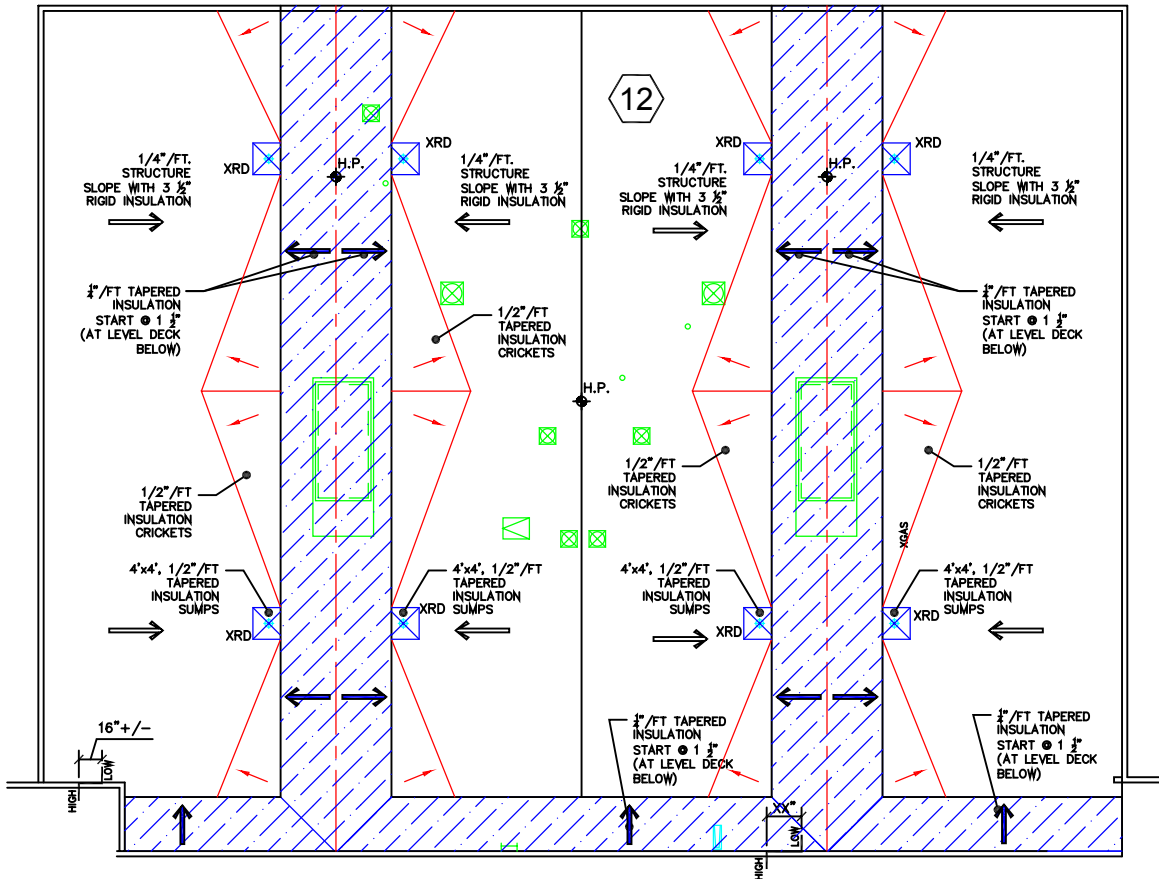

DRAWING LEGEND	
	Roof Drain Location With 4'x4', 1/2\"/>
	New 1/4\"/>
	One (1) Layer of 2.0\"/>
	Roof Area Designation
	New 1/2\"/>
	Tapered Polyiso Ridge/High Point

A

Adhesion - The state in which two surfaces are held together by interfacial forces which may consist of molecular forces or interlocking action or both. Measured in shear and peel modes.

Aggregate - (1) Crushed stone, crushed slag, or water-worn gravel used for surfacing a built-up roof; (2) Any granular mineral material.

Application Rate - The quantity (mass, volume or thickness) of material applied per unit area.

Approval drawings - Approval Drawings may include framing drawings, elevations and sections through the building as furnished by the manufacturer for approval of the buyer. Approval by the buyer affirms that the manufacturer has correctly interpreted the overall contract requirements for the system and its accessories, and the exact location of accessories in the building.

Architectural drawing - A drawing which shows the plan view and/or elevations of the finished building for the purpose of showing the general appearance of the building, indicating all accessory locations.

Ash - The incombustible material that remains after a substance has been burned.

Asphalt - A dark brown to black cementitious material in which the predominating constituents are bitumens, which occur in nature or are obtained in petroleum processing.

Asphalt felt - asphalt-saturated felt.

Asphaltite - A natural asphalt found below ground level.

ASTM - American Society for Testing and Materials.

B

Backnailing - The practice of blind-nailing roofing felts to a substrate in addition to hot mopping to prevent slippage.

Ballast - Loose aggregate, concrete pavers, or other material designed to prevent wind-uplift or flotation of a loose-laid roof system.

Base ply - The bottom or first ply in a built-up roofing membrane when additional plies are to be subsequently installed.

Base sheet - A product intended to be used as a base ply in a built-up roofing system (i.e., a saturated or coated felt).

Bill of materials (B.O.M.) - A list of items or components used for fabrication, shipping, receiving, and accounting purposes.

Bitumen - (1) A class of amorphous, black or dark colored, (solid, semisolid, or viscous) cementitious substances natural or manufactured, composed principally of high molecular weight hydrocarbons, soluble carbon disulfide, and found in asphalts, tars, pitches, and asphaltites; (2) A generic term used to denote any material composed principally of bitumen; (3) In the roofing industry there are two basic bitumens: asphalt and coal tar pitch. Before application they are either (a) heated to a liquid state, (b) dissolved in a solvent, or (c) emulsified.

Block or thermal insulation - Rigid or semi rigid thermal insulation preformed into rectangular units.

Blocking - (1) Wood built into a roofing system above the deck and below the membrane and flashing to (a) stiffen the deck around an opening, (b) act as a stop for insulation, (c) serve as a nailer for attachment of the membrane or flashing. (2) Wood cross-members installed between rafters or joists to provide support at cross-joints between deck panels. (3) Cohesion or adhesion between similar or dissimilar materials in roll or sheet form that may interfere with the satisfactory and efficient use of the material.

British thermal unit (BTU) - The amount of heat required to raise the temperature of one pound of water by 1°F. A wooden kitchen match yields approximately one BTU.

Brooming - Embedding a ply by using a broom to smooth it out and ensure contact with the adhesive under the ply.



Exton, PA 19341 • (888) 594-6700 • Wexford, PA 15090
ShawnM@prarfg.com www.prarfg.com



Published Feb. 2019

Glossary A to B

Building code - Published regulations and ordinances established by a recognized agency describing design loads, procedures, and construction details for structures. Usually applying to designated political jurisdiction (city, county, state, etc.). Building codes control design, construction, and quality of materials, use and occupancy, location and maintenance of buildings and structures within the area for which the code was adopted. (see Model codes)

Built-up Roofing - A continuous, semiflexible membrane consisting of plies of saturated felts, coated felts, fabrics or mats assembled in place with alternate layers of bitumen, and surfaced with mineral aggregate, bituminous material, or a granular surfaced sheet.

C

Canopy - Any overhanging or projecting roof structure with the extreme end usually unsupported.

Cant Strip - A beveled strip used under flashings to modify the angle at the point where the roofing or waterproofing membrane meets any vertical surface.

Cap Flashing - See Flashing.

Cap Sheet - A granule-surfaced coated felt used as the top ply of a built-up roofing membrane.

Condensation - The conversion of the water vapor or other gas to liquid as the temperature drops or atmospheric pressure rises.

Conductance, thermal - The thermal transmission in the unit time through unit area of a particular body or assembly having defined surfaces, when unit average temperature difference is established between the surfaces.

$C=(W/m^2 \cdot K)$ $C=(Btu/h \cdot ft^2 \cdot ^\circ F)$.

Conductivity (thermal) - The time rate of transfer of heat by conduction through a unit thickness across unit area for unit difference of temperature.

Conductivity, thermal - The thermal transmission, by conduction only, in unit time through unit area between two isothermal surfaces of an infinite slab of a homogeneous material of unit thickness, in a direction perpendicular to the surface, when unit temperature difference is established between the surfaces.

$k=(W/m \cdot K)$ ($k=(Btu/h \cdot ft^2 \cdot ^\circ F)$)

Cricket - Elevated area of a roof constructed to divert water from a horizontal intersection of the roof with a chimney, wall, expansion joint or other projection.

Curb - A raised member used to support roof penetrations such as skylights, hatches, etc.

D

Dead level roofing - A roofing system applied on a surface with a 0 to 2% incline.

Dead load - The dead load of a building is the weight of all permanent construction, such as floor, roof, framing, and covering members.

Deck - The structural surface to which the roofing or waterproofing system (including insulation) is applied.

Deflection - The displacement of a structural member or system under load.

Deflection - Crosshead movement after the loading plates contract the specimen. It is expressed in millimeters or inches. (ASTM D-1621)

Deflection - The change in mid-span position of a test specimen during a creep test.

Degree days - The difference between a reference temperature (usually 65) and the mean temperature for the day times 24 hours times the number of days in the period. Degree days is used to compare the severity of cold or heat during the heating or cooling season.

Dew point - The temperature at which water vapor starts to condense in cooling air at the existing atmospheric pressure and vapor content.

E

Eave - The line along the sidewall formed by the intersection of the planes of the roof and wall.

Edge venting - The practice of providing regularly spaced protected openings at a roof perimeter to relieve water vapor pressure in the insulation.



Exton, PA 19341 • (888) 594-6700 • Wexford, PA 15090
ShawnM@prarfg.com www.prarfg.com



Published Feb. 2019

Glossary B to E

Page 30

Embedment - (1) The process of pressing a felt, aggregate, fabric, mat, or panel uniformly and completely into hot bitumen or adhesive to ensure intimate contact at all points. (2) The process of pressing granules into coating in the manufacture of factory prepared roofing, such as shingles.

EVT (Equiviscous Temperature) - The temperature at which the viscosity of an asphalt is appropriate for application. Viscosity units are generally expressed in centipoise or centistokes. Tolerance on EVT is usually $\pm 25^{\circ}\text{F}$ ($\pm 14^{\circ}\text{C}$).

Expansion joint - A structural separation between two building elements that allows free movement between the elements without damage to the roofing or the waterproofing system.

F

Factory square - The amount of roofing material supplied to cover 100 sq.ft. of roof area. 10m² (108 ft.2).

Fiber glass insulation - Blanket insulation, composed of glass fibers bound together with a thermoset binder, faced or unfaced, used over or under purlins to insulate roofs and walls, semirigid boards, usually with a facer.

Flashing - The system used to seal membrane edges at walls, expansion joints, drains, gravel stops, and other places where the membrane is interrupted or terminated. Base flashing covers the edges of the membrane. Cap or counter flashing shields the upper edges of the base flashing.

FMG - Factory Mutual Global provides commercial and industrial property insurance and a variety of risk management services for property loss prevention engineering and research.

G

Gravel stop - A flanged device, frequently metallic designed to prevent loose aggregate from washing off the roof and to provide a continuous finished edge for the roofing.

Gutter - A channel member installed at the eave of the roof for the purpose of carrying water from the drains or down spouts.

H

Heat transfer - The transmission of the thermal energy from a location of higher temperature to a location of lower temperature. This can occur by convection or radiation.

Hip roof - A roof which rises by inclined planes from all four sides on the building. The line where two adjacent sloping sides of a roof meet is called the Hip.

Humidity - The amount of moisture contained in the atmosphere. Generally expressed percent relative humidity. (The ratio of the vapor pressure to the saturation pressure for given conditions times 100.)

Humidity test - A test involving exposure of specimens at controlled levels of humidity and temperature.

I

IBC - The International Building Code, developed and written by The ICC. Comprehensive code provides safety concepts for all buildings and the latest industry standards in material designs.

ICC - The International Code Council, association dedicated to building safety and fire prevention, develops the codes to construct residential and commercial buildings. Dedicated to developing a single set of comprehensive and coordinated national model construction codes.

Incline - The slope of a roof expressed in percent or in the number of vertical units of rise per horizontal unit of run.

Insulation, thermal - Any material used in building construction to reduce heat transfer.

Isocyanate - A highly reactive chemical grouping composed of a nitrogen atom bonded to a carbon atom bonded to an oxygen atom: =N=C=O; a chemical compound, usually organic, containing one or more isocyanate groups.

L

LTTR - Long Term Thermal Resistance (LTTR) is a scientifically supported way to calculate the 15-year, time-weighted average R-value of roof insulation. Most polyiso. manufacturers have adopted the LTTR method as the exclusive means to measure thermal performance of permeable-faced Polyiso. roof insulation.

M

Moisture conduction - Migration by wicking as contrasted to vapor movement.

Mop - and - flop - A procedure in which roofing elements (insulation boards, felt plies, caps sheets, etc.) are initially placed upside down adjacent to their ultimate locations, are coated with adhesive, and are then turned over and adhered to the substrate.



Exton, PA 19341 • (888) 594-6700 • Wexford, PA 15090
ShawnM@prarfg.com www.prarfg.com



Published Feb. 2019

Glossary E to M

Page 31

Mopping - The application of hot bitumen with a mop or mechanical applicator to the plies of a built-up roof. There are four types of mopping:

(1) solid - a continuous coating; (2) spot - bitumen is applied in roughly circular areas, generally about 18 in. (460 mm) in diameter, leaving a grid of unmopped, perpendicular area; (3) strip - bitumen is applied in parallel bands, generally 8 in. (200 mm) wide and 12 in. (300 mm) apart; (4) sprinkle - bitumen is shaken on the substrate from a broom or mop in a random pattern.

P

Peak - The uppermost point of a gable.

Perlite - An aggregate used in lightweight insulating concrete and in preformed perlite insulating board: formed by heating and expanding siliceous volcanic glass.

Perm - (vapor transmission) - A unit to measure water vapor transmission - one grain of water per square foot per hour per inch of mercury pressure difference.

1 Perm=1 grain/h•ft²•in.Hg

Permeability - (1) The capacity of a porous medium to conduct or transmit fluids; (2) The amount of liquid moving through a barrier in a unit time, unit area and unit pressure gradient not normalized for but directly related to thickness; (3) The product of vapor permeance and thickness (for thin file, ASTM E96- over 1/8", ASTM C355).

Permeance - The rate of water vapor transmission per unit area at a steady state through a membrane or assembly. expressed in ng/Pa•s•m²•h•in. Hg).

Pond - A surface which is incompletely drained.

R

Rafter - One of a series of structural members designed to support roof loads. The rafters of a flat roof are sometimes called roof joists.

Rake - The sloped edge of a roof at the first or last rafter.

Rake angle - Angle fastened to purlins at rake for attachment of end wall panels.

Rake trim - A flashing designed to close the opening between the roof and end wall panels.

Relative humidity - The ratio of the mass per unit volume (or partial pressure) of water vapor in an air-vapor mixture to the saturated mass per unit volume (or partial pressure) of the water vapor at the same temperature, expressed as a percentage.

Resistance, thermal - The average temperature difference between two defined surfaces of a particular body assembly when unit thermal transmission in unit time through unit area established between the surfaces.

Ridge - Highest point on the roof of the building which describes a horizontal line running the length of the building.

RIEI - The Roofing Industry Educational Institute.

Roof overhang - A roof extension beyond the end wall / side wall of a building.

Roof slope - The angle a roof surface makes with the horizontals, measured in the number of inches of vertical rise in 12" of horizontal length. Examples ¼"/ft. or 1:48 or 2%.

Roofing system - An assembly of interacting components designed to weatherproof, and normally to insulate, a building's top surface.

S

Saddle - A small structure that helps to channel surface water to drains. Frequently located in a valley, a saddle is often constructed like a small hip roof or like a pyramid with a diamond shape base. (Also See Cricket).

Sales square - The quantity of prepared roofing required to cover (100 ft.²) of deck.

Scupper - Channel through parapet, designed for peripheral drainage of the roof, usually a safety overflow to limit accumulation of ponded rainwater caused by clogged drains.

SI - The international symbol for the metric unit (Le Systeme International d'Unites).

Slope - The tangent of the angle between the roof surface and the horizontal plane, expressed as a percentage, or in inches of rise per foot of horizontal distance. (See Also Incline).

Specifications - A statement of particulars of a given job, as to size of building, quality, and performance of men and materials to be used, and the terms of the contract.

Square - A roof area of (100 ft.2).

Substrate - The surface upon which the roofing or waterproofing membrane is placed (structural deck or insulation).

Sump - A depression around a drain.

T

Tapered edge strip - A tapered insulation used to elevate the roof at the perimeter and at penetrations of the roof.

Tensile strength - (1) The maximum tensile stress per unit of original cross sectional area applied during stretching of a specimen to break; SI-metric - Megapascal or kilopascal, customary pound per square inch; (2) The longitudinal pulling stress a material can bear without tearing apart; (3) The ratio of maximum load to original cross-sectional area. Also called ultimate strength.

Therm - A unit of heat commonly used by utilities quoting prices or cost. It is equivalent to 100,000 BTU.

Thermal bridge - Interruption of a layer of thermal insulation by a material of high thermal conductivity (e.g., metal).

Thermal conductance (C) - The rate of heat flow, in BTU's per hour, through a square foot of material or a combination of material whose surfaces have a temperature difference of 1°F.

Thermal conductivity (k) - The rate of heat flow, in BTU's per hour, through a square foot of material exactly one inch thick whose surfaces have a temperature difference of 1°F.

Thermal insulation - A material applied to reduce the flow of heat.

Thermal resistance (R) - Resistance to heat flow. The reciprocal of conductance (C).

Thermal shock - The stress producing phenomenon resulting from sudden temperature drops in a roof membrane when, for example, a rain shower follows brilliant sunshine.

Thermoplastic - Capable of being repeatedly softened by increase of temperature and hardened by decrease in temperature. The thermoplastic form allows for easier seaming both in the factory and in the field.

Thermoset - A material that will undergo or has undergone a chemical reaction by the action of heat, catalysts, ultraviolet light, etc., leading to a relatively infusible state.

U

Uplift - Wind load on a building which causes a load in the upward direction.

V

Valley gutter - A channel used to carry off water from the "V" of a roof. This condition is usually created when two buildings are joined side by side.

Vapor barrier - (More precisely, vapor retarder). A layer of material used to appreciably reduce the flow of water vapor into thermal insulation from the high vapor pressure side.

Vapor migration - The movement of water vapor from a region of high vapor pressure to a region of lower vapor pressure.

Vapor pressure - The pressure exerted by a vapor that is in equilibrium with its solid or liquid form.

Vapor retarder - A material that provides a resistance to the transmission of water vapor under specified conditions.

Vermiculite - An aggregate used in lightweight insulating concrete, formed by heating and expanding a micaceous mineral.

W

Water vapor transmission - (WVT) - Water vapor flow normal to two parallel surfaces of a material, through a unit area, under the conditions of a specified test such as ASTM E96.

Customary units are grains/h•ft².

Wicking - The process of moisture movement by capillary action as contrasted to movement of water vapor.

Wind load - A load caused by the wind blowing from any horizontal direction.



Exton, PA 19341 • (888) 594-6700 • Wexford, PA 15090
ShawnM@prarfg.com www.prarfg.com



Published Feb. 2019

Glossary S to W

Page 33

R-Value, Thermal Resistance ($\text{ft}^2 \cdot \text{h} \cdot ^\circ\text{F} / \text{Btu}$) or ($\text{m}^2 \cdot \text{K} / \text{W}$): A measure of ability to retard heat flow as opposed to the ability to transmit heat. R is the numeric reciprocal of U or C, thus $R = 1/U$ or $1/C$. A U-Value of 0.05 has an R-Value of $1/0.05$ or 20. Products having the same R-Value are equal in insulating value regardless of the material type or thickness. Higher R means better insulating qualities. R-Values are generally used to compute the overall insulating value of an assembly because the individual component R-Values can be added. The reciprocal of the total R-Value ($1/R = U$) for the assembly results with the assembly U-Value.

LTTR Value, Long Term Thermal Resistance: Same as R-Value but is based on the CAN/ULC S770 test method as noted in ASTM C 1289-02. The CAN/ULC S770 test method was developed to determine Long Term Thermal Resistance (LTTR) using two methods, slicing and scaling. These procedures provide a 15 year time weighted average for polyiso roof insulation. This provides a more descriptive measure of the long-term thermal resistance of polyiso insulation.

K-Value, Thermal Conductivity: ($\text{ft} \cdot \text{h} \cdot ^\circ\text{F}$) or ($\text{W} / (\text{m} \cdot \text{K})$): A measure of a materials ability to conduct heat. This value is based upon the amount of heat passing through a homogeneous material 1" thick and 1 square foot in area in 1 hour with a 1°F temperature differential between the two surfaces. The lower the K, the higher (better) the insulating value. A K-Value of 0.17 has an R-Value per inch of $1/0.17$ or 5.88.

U-Value, Overall Coefficient of Heat Transmission: ($\text{ft}^2 \cdot \text{h} \cdot ^\circ\text{F}$) or ($\text{W} / (\text{m}^2 \cdot \text{K})$): The combined thermal value of all the materials in a building section. This value generally includes all of the components from the outside air film to the inside air film. The lower the U, the higher (better) the insulating value. A U-Value of 0.05 has an R-Value of $1/0.05$ or 20.

C-Value, Thermal Conductance: ($\text{ft}^2 \cdot \text{h} \cdot ^\circ\text{F}$) or ($\text{W} / (\text{m}^2 \cdot \text{K})$): Similar to conductivity (K-Value) but for thickness' other than 1" or materials that are not homogeneous (solid foam or other insulation material, no facers). Values are also based upon a 1 square foot area, 1°F temperature difference and a 1 hour time frame. A C-Value of 0.12 has an R-Value of $1/0.12$ or 8.33.